

Pavement Loading & Deformation Testing

of Plastic Edge Restraints for Segmental Pavements

Testing Proves PAVE EDGE[®]
Outperforms Other
Leading Edge Restraints.



Every project from small residential patios to large container ports benefit from the superiority of an engineered segmental pavement system. The projects look better and most importantly, outperform other pavement options. Thanks to dedicated manufacturers, contractors and suppliers in North America, many standards and specifications have been developed over the last 30 years. These standards created by the Interlocking Concrete Pavement Institute (ICPI) and the Brick Industry Association (BIA) have greatly improved the quality of the pavers and installation.



Currently there is no industry specification for one of the most important components of a flexible paver system . . . the edge restraint. Equally as important as proper base and durable pavers, the edge restraint holds the entire pavement together. Flexible paver systems, whether interlocking concrete or clay pavers, only perform when there is interlock between the units. The interlock of the pavers is what allows loads on the surface to be distributed to the surrounding units, no matter if it is pedestrian or vehicular traffic. Once the edge of an interlocking pavement shifts out, the project is compromised. If an edge restraint shifts, the joints begin to open up. Failure will follow, but may not be immediately noticeable.

Common reasons flexible paver systems can fail:

- Base not thick enough for type of traffic load
- Poor base compaction
- Insufficient base extension
- Bedding sand layer too thick or uneven
- Improper paver aspect ratio for the type of traffic load
- Edge restraint failure

Today's professional paver contractors strive to follow industry installation specifications. Problems are being avoided and projects are lasting longer. No standards or specifications have been developed to measure the holding ability of edge restraints.

Segmental pavement system interlock is critical to the performance and life of the pavement. Edge restraint failure effects interlock. PAVE TECH, INC. engaged Stork Twin City Testing Corporation (Stork), an engineering and testing company located in St. Paul, Minnesota, to design a test that could measure comparable performance of the most common manufactured plastic paver edge restraints (edge restraints) on the market.

TEST VARIABLES:

- **Material (type of plastic)**
- **Design**
- **Spiking frequency**

An edge restraint's responsibility is to withstand horizontal loads created by inherent pavement energy and traffic. **Pavement Energy** is the constant pressure of pavers against each other. **Traffic loads** are the momentary dynamic forces imparted by traffic. All functioning segmental pavements, no matter the size or application, have pavement energy which can only be created when the components of the paver system are properly installed.

Components of a segmental pavement system consist of:

- Sub-base
- Base
- Bedding & Joint Sand
- Pavers
- Bond Pattern
- Edge Restraint

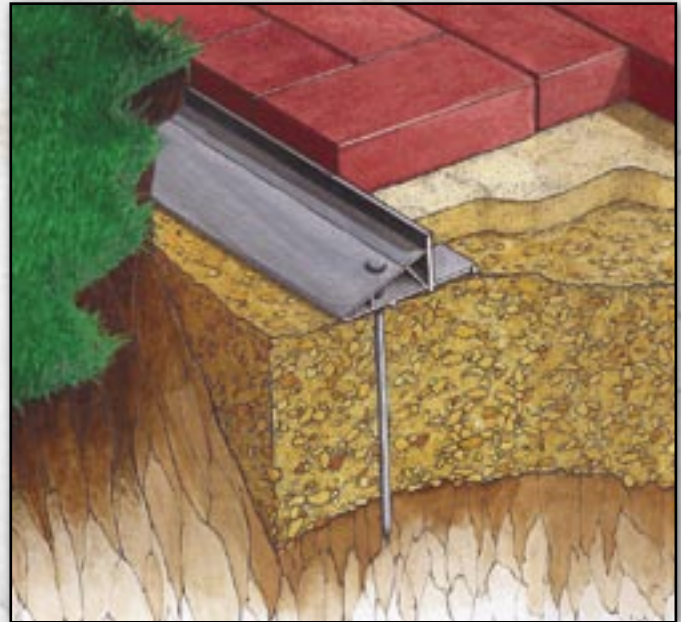

This image shows the different components needed to create a long lasting pavement.

Important considerations include:

- Compaction
- Drainage/Grade
- Paver Shape
- Paver Aspect Ratio

Deflection of edge restraint:

- Is the movement of the edge under load
- Becomes deformation when it does not return to its original state

Pavement Energy:

- is created by compaction and filling of the joints.
- in the field of the pavement is created and held by the bond pattern and surrounding pavers.
- is maintained around the perimeter by structures, concrete curbs or manufactured edge restraints.
- and lock up does not exist at the onset of the compaction process. At this stage all of the components act independently. The first passes of the compactor along the perimeter apply the greatest horizontal load to the edge restraints they will typically ever receive. Load sharing starts to occur once the paver system begins lock-up, creating pavement energy.
- will continue to increase with pavement use.

Edge restraint **Failure** is the horizontal shifting or permanent deformation under load. When the pavement shifts out, the joints open and interlock along the perimeter deteriorates. As the edge continues to shift out, this deterioration will continue to work into the pavement at an accelerating rate.



Pavement unzipping due to edge restraint failure.

Stork designed the tests to measure **Deformation** (permanent edge restraint shift) and **Load** (pavement energy). The measurements were taken immediately after compaction when the edge restraint was the most susceptible to shifting. The ideal edge restraint withstands horizontal loads without permanent deformation.



Edge restraint failure from improper product use. Flexible was used where rigid should have been used.

It is important to note that not all edge restraints are manufactured using the same type of plastic. There are three plastics most commonly used to produce edge restraints.

DEFINITION OF PLASTICS' PROPERTIES

- **Polyethylene**
is a synthetic polymer of ethylene, Which is not considered a structural plastic and does not have "memory". When deformed it stays deformed.
- **Polypropylene**
a versatile thermoplastic substance that is a synthetic polymer of propylene. Polypropylene is a mid-price, mid-grade structural plastic.
- **Polyvinyl Chloride (PVC)**
is a tough, hard-wearing synthetic resin made by polymerizing vinyl chloride. PVC is a more expensive and structural plastic that will return to its original state after load is removed.

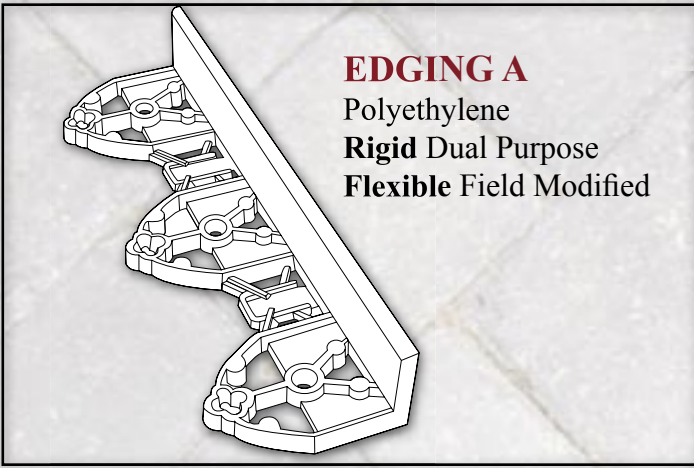

EDGING A
 Polyethylene
Rigid Dual Purpose
Flexible Field Modified

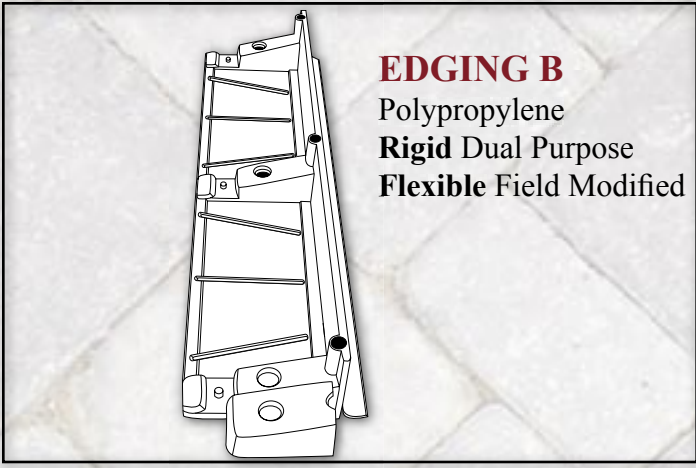

EDGING B
 Polypropylene
Rigid Dual Purpose
Flexible Field Modified

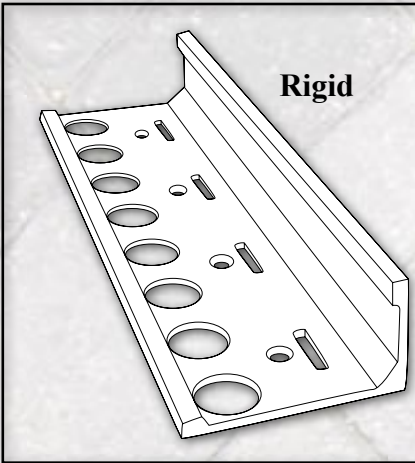

Rigid

EDGING C
 Polyvinyl Chloride (PVC)
Rigid
Flexible

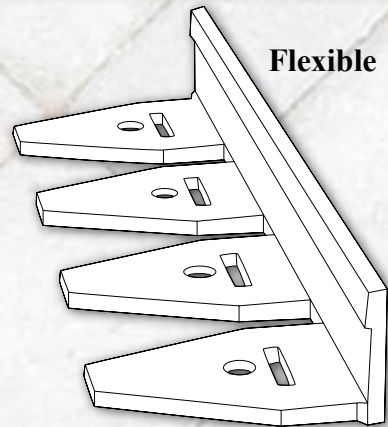

Flexible

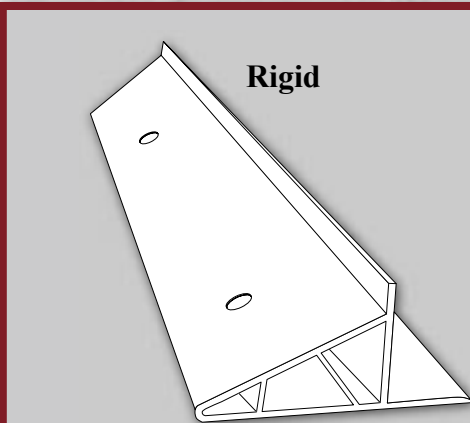

Rigid

EDGING D (PAVE EDGE)
 Polyvinyl Chloride (PVC)
Rigid
Flexible

**Testing Proves PAVE EDGE
 Outperforms Other
 Leading Edge Restraints.**

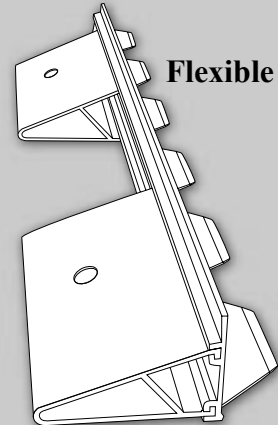

Flexible

DEFINITION OF EDGING DESIGN

Rigid edgings are those that are designed to resist flexing or curving and to be used along straight perimeters. Some rigid edgings are dual purpose by design and can easily be field modified by cutting, to make them flexible. Flexible edgings are specifically designed for curved areas. The test products are divided into the following categories:

- **Rigid**
- **Rigid Dual Purpose**
- **Flexible**
- **Flexible Field Modified**

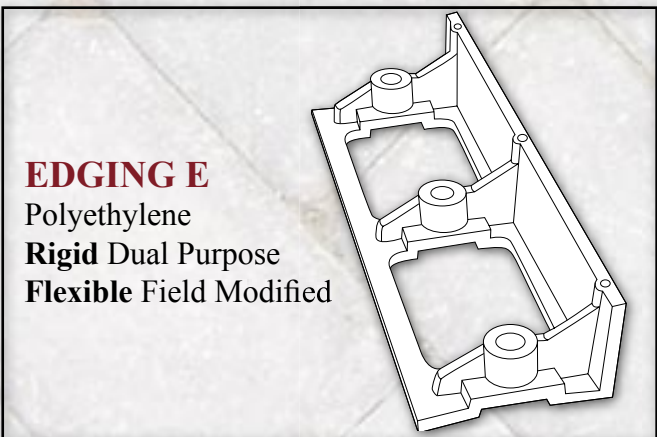

EDGING E
 Polyethylene
Rigid Dual Purpose
Flexible Field Modified

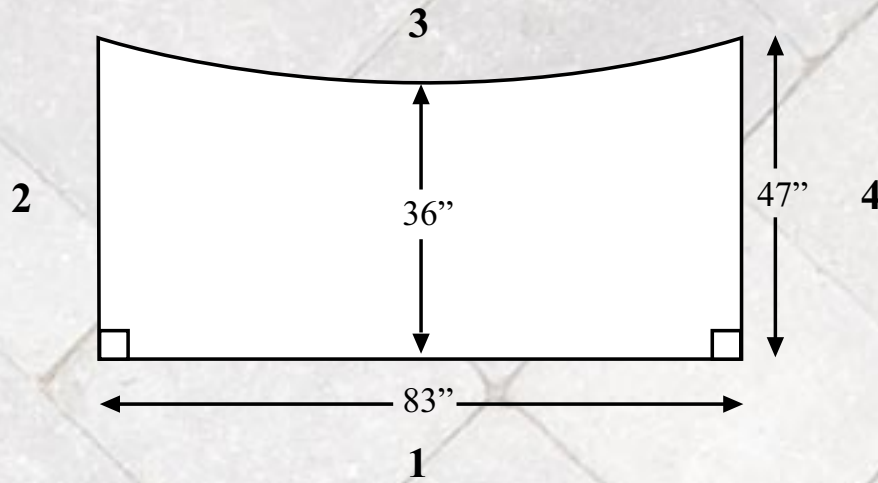

All dimensions are nominal.

TEST AREA DETAILS (constructed according to ICPI/BIA specifications)

The design chosen for the test reflects common perimeter configurations found on actual projects. A concave (inward) curve was selected as it is more susceptible to deflection than a convex (outward) curve.

- Base - 18" minimum depth $\frac{3}{4}$ " minus crushed limestone base
- Pavers - 100mm x 200mm x 60mm concrete pavers (1.5mm spacer bars)
- Pattern - 90° herringbone
- Bedding - 1" layer of loose screeded coarse washed sand
- Edge restraints on sides 1, 2 & 3 were installed before the sand and pavers were placed. Side 4 was installed after sand and pavers were placed to allow full and one half paver units. There are no known or observed differences in the holding ability of any plastic edge restraint installed either before or after pavers have been laid.
- All the edge restraint systems were installed using 10" long x $\frac{3}{8}$ " diameter smooth steel spikes.



10" x $\frac{3}{8}$ " steel spike used to spike edging.

On the first day of testing, the spikes were spaced according to each edging manufacturer's recommendations. On the second day using new test areas, the spiking of rigid edging was spaced nominally at 24" (61cm) and flexible edging was spaced nominally at 10 $\frac{1}{2}$ " (27cm). The spiking frequency used on the second day will be referred to as Test Recommended Spacing.



Spiking spaced according to Test Recommended Spacing.

- Cutting was done on a masonry table saw allowing gaps no larger than $\frac{3}{16}$ ". All other areas used full and half units laid hand tight.
- Compactor Specifications:
 - Dead Weight 275 lbs (125 kg)
 - Centrifugal Force 4946 lbs (22 kN)
 - Plate Size 384 sq in (2477 cm²)

Joel Lessard an engineer from Stork supervised the compaction and conducted the testing, data recording and produced the report. The raw data report from Stork is available online. www.pavetech.com/paveedge/report.shtm

Deformation in Relation to Spike Spacing

Manufacturers's Recommended Specifications

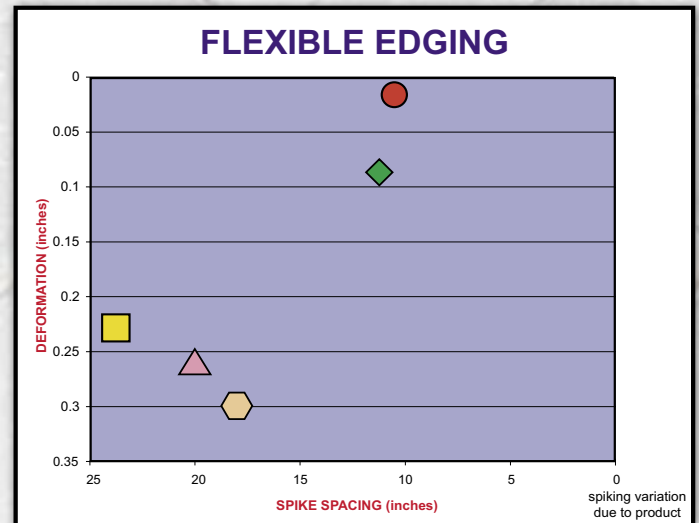
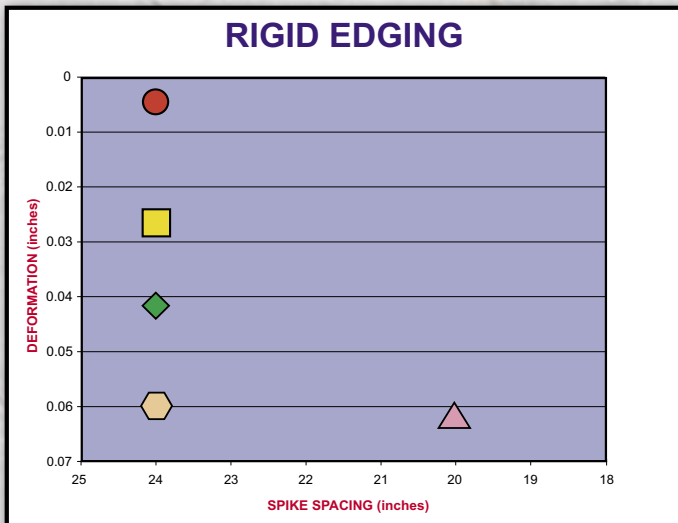

On the first day of testing, the spikes were spaced according to each manufacturer's specifications.

Spike Spacing Recommendations

		Manufacturer Specifications		Test Specifications	
EDGING	TYPE OF PLASTIC	RIGID	FLEXIBLE	RIGID	FLEXIBLE
△ A	Polyethylene	20	20	20	12
◇ B	Polypropylene	24	12	24	12
⬡ C	PVC	24	18	24	12
● D	PVC (PAVE EDGE)	24	10.5	24	10.5
■ E	Polyethylene	24	24	24	12

BEST PERFORMER

Test Recommended Specifications

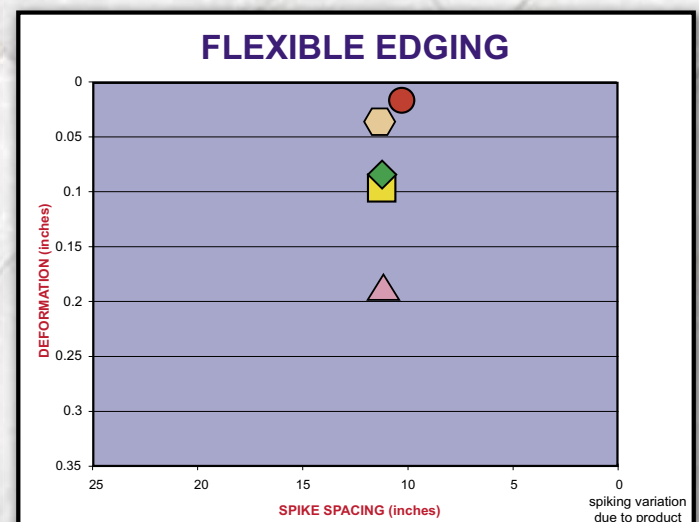
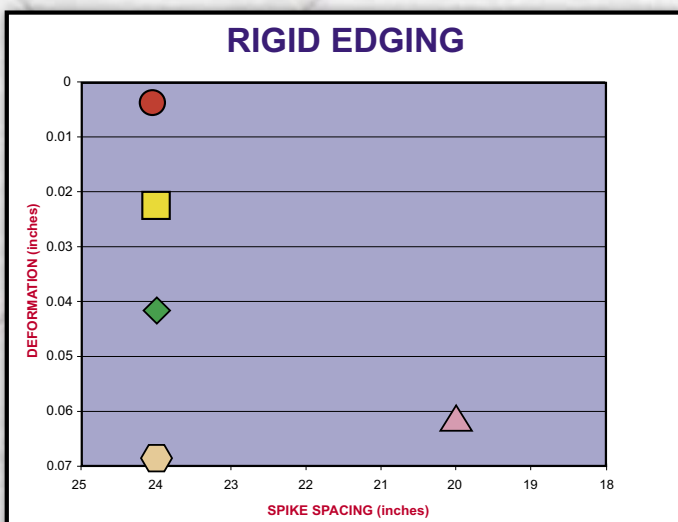

On the second day using new test areas, the spiking of rigid edging was spaced nominally at 24". Flexible edging was spaced nominally at 10½".

Deformation / Load Correlation

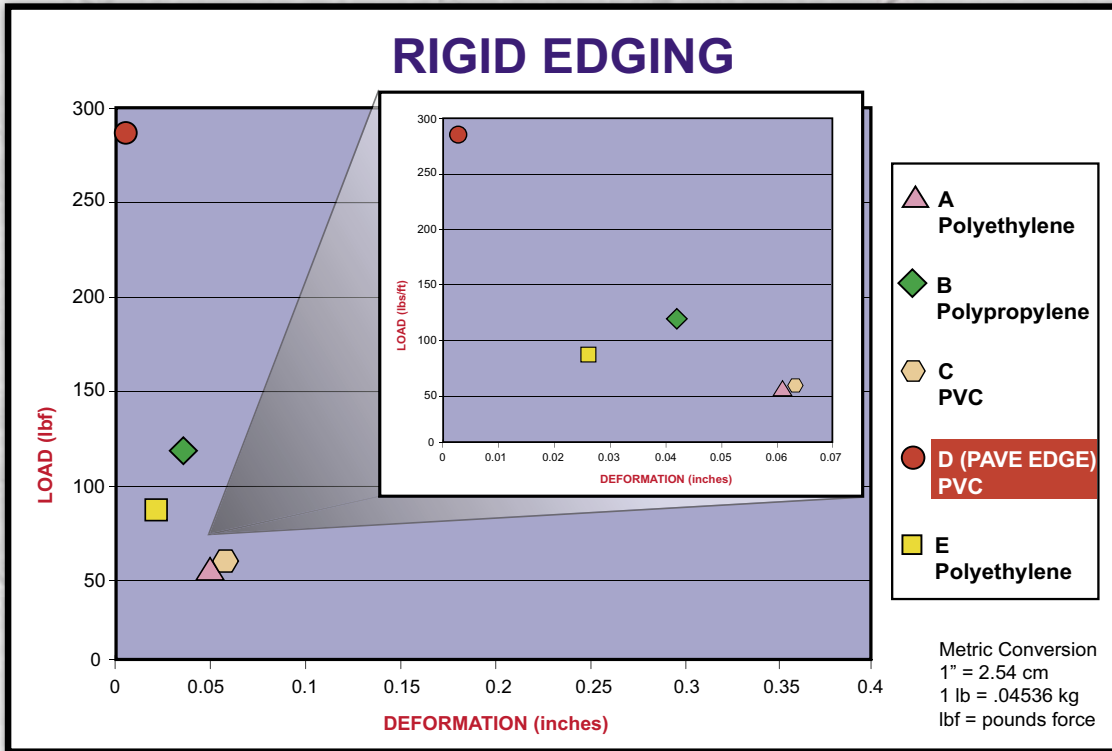

This chart shows the correlation between **Deformation** and **Load** on the rigid edging.

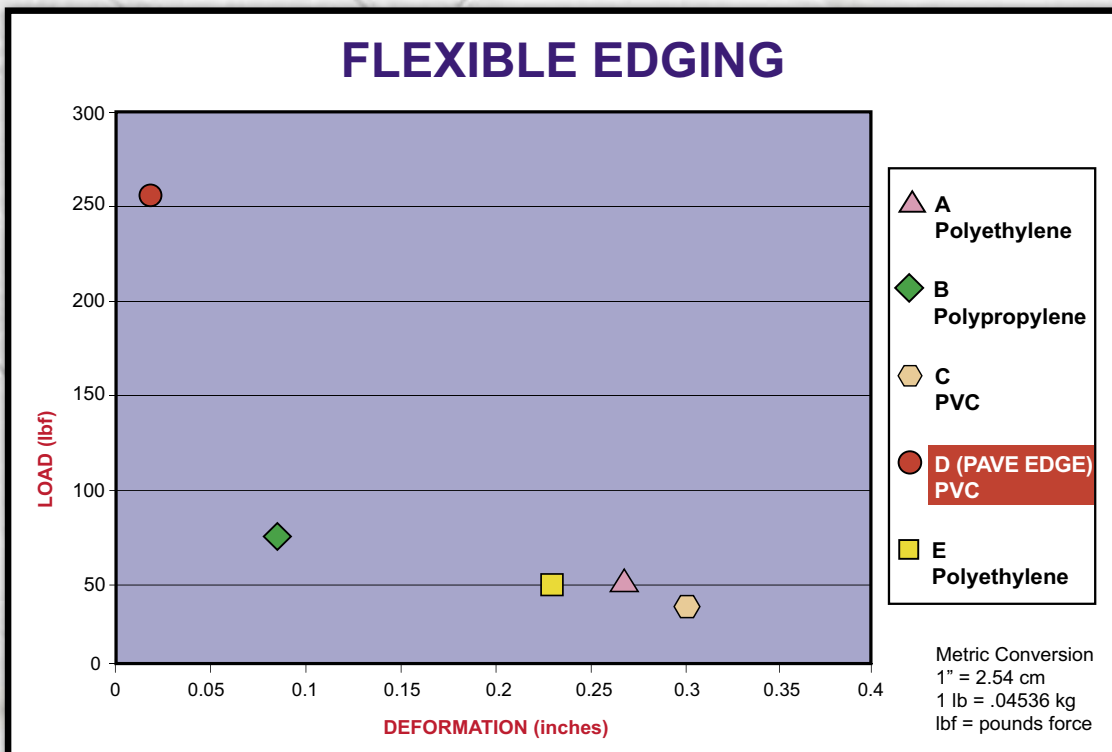

This chart shows the correlation between **Deformation** and **Load** on the flexible edgings.

Images after Compaction

DEFLECTIONS ON DAY 1

DEFLECTIONS ON DAY 2



EDGING A

Manufacturer's recommended spike spacing.



EDGING A

Test recommended spike spacing.



**No Additional
Testing Required**

EDGING B - Only Tested on Day 2.
No additional testing was required.



EDGING B - Manufacturer's and Test
recommended spike spacing are the same.

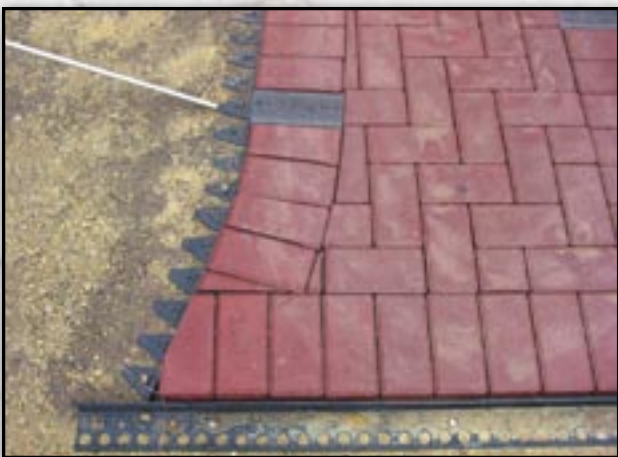

EDGING C

Manufacturer's recommended spike spacing.



EDGING C

Test recommended spike spacing.

Images after Compaction

DEFLECTIONS ON DAY 1



EDGING D - Manufacturer's and Test recommended spike spacing are the same.



EDGING E
Manufacturer's recommended spike spacing.

DEFLECTIONS ON DAY 2



No Additional Testing Required

EDGING D - Only Tested on Day 1. No additional testing was required.



EDGING E
Test recommended spike spacing.



Testing equipment for data recording load sensing steel pavers.



Installation of load sensing steel pavers.

DEFORMATION TEST

(Measurement of Permanent Edge Restraint Shift)

DEFORMATION - Inches

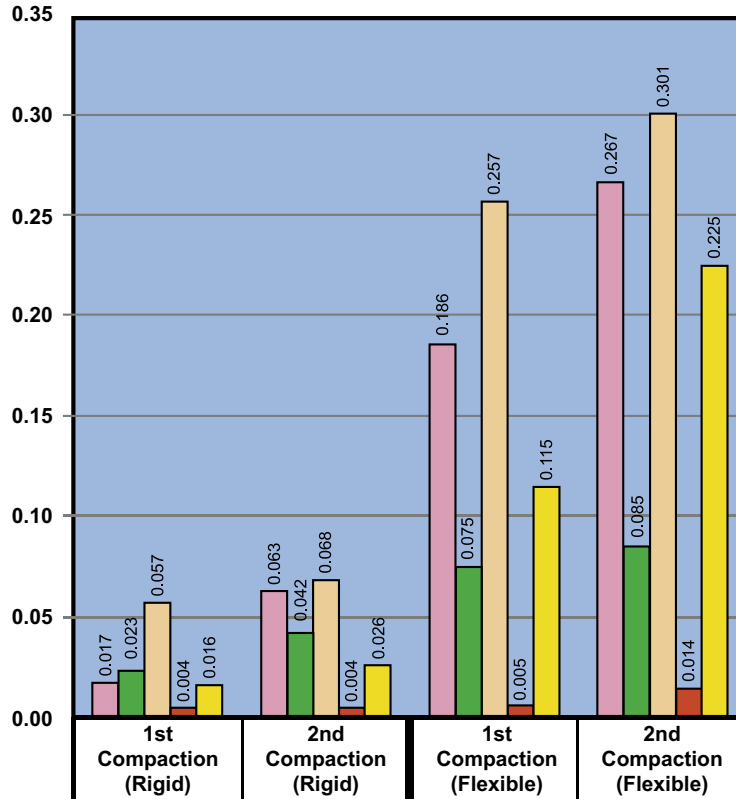

Metric Conversion
1" = 25.4 mm

<div style="display: flex; align-items: center;"> <div style="width: 10px; height: 10px; border: 1px solid black; background-color: #f08080; margin-right: 5px;"></div> A Polyethylene </div>	0.017	0.063	0.186	0.267
<div style="display: flex; align-items: center;"> <div style="width: 10px; height: 10px; border: 1px solid black; background-color: #38a838; margin-right: 5px;"></div> B Polypropylene </div>	0.023	0.042	0.075	0.085
<div style="display: flex; align-items: center;"> <div style="width: 10px; height: 10px; border: 1px solid black; background-color: #f0e68c; margin-right: 5px;"></div> C PVC </div>	0.057	0.068	0.257	0.301
<div style="display: flex; align-items: center;"> <div style="width: 10px; height: 10px; border: 1px solid black; background-color: #8b0000; margin-right: 5px;"></div> D (PAVE EDGE) PVC </div>	0.004	0.004	0.005	0.014
<div style="display: flex; align-items: center;"> <div style="width: 10px; height: 10px; border: 1px solid black; background-color: #ffff00; margin-right: 5px;"></div> E Polyethylene </div>	0.016	0.026	0.115	0.225

BEST PERFORMER

The DEFORMATION TEST chart above shows the distance of permanent edge restraint shift. Baseline measurements were taken prior to compaction. All measurements were taken after compaction.



Deflection measurement was taken midway between spikes.

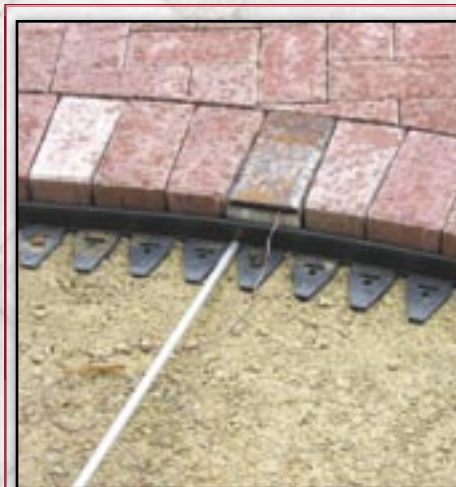

Even with properly compacted base material, spikes will shift slightly during initial compaction. Spikes shift until they are "seated" in the base. The shifting of a spike after compaction showed a measurement of:

1st compaction = 0.014"
2nd compaction = 0.045"

LOAD TEST

(Pavement Energy Measurement)

LOAD - (Lbf)

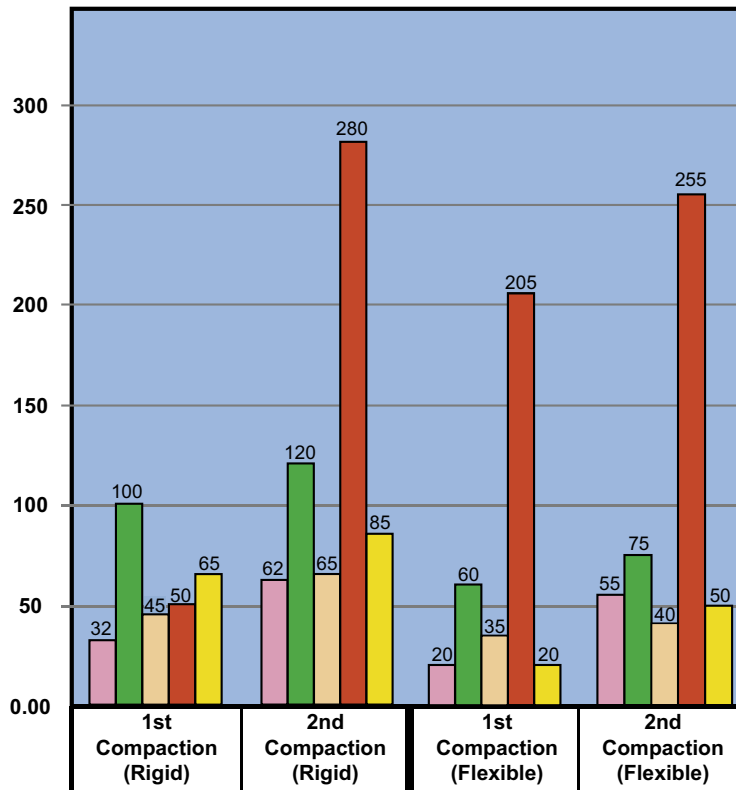

Metric Conversion
1 lbf = 4.45 N

<div style="display: flex; align-items: center;"> <div style="width: 10px; height: 10px; background-color: #f080f0; border: 1px solid black; margin-right: 5px;"></div> <div> <p>A Polyethylene</p> </div> </div>	32	62	20	55
<div style="display: flex; align-items: center;"> <div style="width: 10px; height: 10px; background-color: #32cd32; border: 1px solid black; margin-right: 5px;"></div> <div> <p>B Polypropylene</p> </div> </div>	100	120	60	75
<div style="display: flex; align-items: center;"> <div style="width: 10px; height: 10px; background-color: #ffd700; border: 1px solid black; margin-right: 5px;"></div> <div> <p>C PVC</p> </div> </div>	45	65	35	40
<div style="display: flex; align-items: center;"> <div style="width: 10px; height: 10px; background-color: #8b0000; border: 1px solid black; margin-right: 5px;"></div> <div> <p>D (PAVE EDGE) PVC</p> </div> </div>	50	280	205	255
<div style="display: flex; align-items: center;"> <div style="width: 10px; height: 10px; background-color: #ffff00; border: 1px solid black; margin-right: 5px;"></div> <div> <p>E Polyethylene</p> </div> </div>	65	85	20	50

BEST PERFORMER

The LOAD TEST data shows the amount of pavement energy in pounds force (lbf) measured by the load sensing steel pavers that Stork manufactured. They were placed within the soldier course (one in the straight section; one in the curved section) before compaction began. Data was collected after compaction.

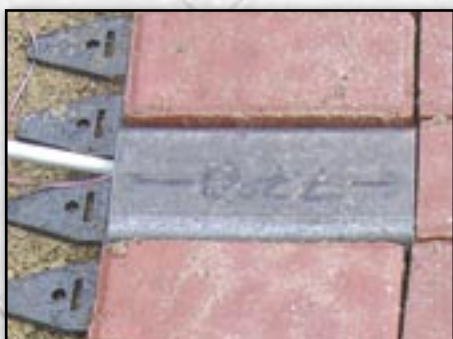

Load sensing steel paver installed with cover on.



Load sensing steel paver.



Close up of the dial indicator.

CONCLUSION

The data shows a clear correlation between how much an edge restraint shifts from initial compaction and the amount of pavement energy restrained. The data also shows that many edge restraints do a poor job of maintaining pavement energy and system interlock. The test data confirms that the test variables are all important aspects of performance.

- **Materials (type of plastics)**
- **Design**
- **Spiking frequency**

This engineering study was done to provide a method by which edge restraint performance could be compared. It is the first data compiled to help better understand the relationship of pavement energy and edge restraint deformation. Segmental pavement systems have been perfected over many decades, some may even say centuries. Manufactured plastic edge restraints are a recent evolution to an already proven system. It is important to build a segmental pavement where all the paver components are designed to perform equally. The goal is to create a segmental pavement system that will last.



This photo, taken in August 2006, shows a PAVE EDGE Industrial installation at Prior Lake Aggregate approaching the pit weigh scale. It was installed by PAVE TECH in 1989 with 8cm rectangular concrete pavers. Every truck in and out of the gravel pit must be weighed twice; once empty and once full. The estimated weight of the loaded trucks going out over the past 17 years totalled in excess of 10,000,000 tons! The original outward shift of the spikes was approximately $\frac{3}{8}$ of an inch within the first month after installation and has never shifted again.



Residential pavements like walkways will typically receive their greatest horizontal load during compaction.

**This report/publication has been issued by
PAVE TECH, INC. based on original
engineering report from Stork Engineering.**

**PAVE TECH, INC.
PO Box 576
Prior Lake, MN 55372
Phone: 1-800-728-3832
Fax: 952-226-6406
www.pavetech.com**

PAVE TECH, INC © 2006 ALL RIGHTS RESERVED

Photo editing limited to brightness and contrast. All line drawings were created from digital images used in the testing.

storkreport0906