

ARCHITECTURAL PRODUCT SPECIFICATION

SEGMENTAL PAVER EDGE RESTRAINTS



There are six components to a typical segmental pavement system. They include sub-base, base, bedding & joint sand, pavers, bond pattern and edge restraint. The edge restraint's responsibility is to withstand horizontal loads created by inherent pavement energy and traffic. Pavement energy is the constant pressure of pavers against each other. Traffic loads are the momentary dynamic forces imparted by traffic.

An independent engineering and testing company tested the leading plastic paver edge restraints to measure Deformation (permanent edge restraint shift) and Load (pavement energy). Edge restraint failure occurs when horizontal shifting becomes permanent deformation under load. Segmental pavement system interlock is critical to the performance and life of the pavement. Edge restraint deformation effects interlock. When the pavement shifts out, the joints open and interlock along the perimeter deteriorates. As the edge continues to shift, this deterioration continues into the pavement at an accelerating rate.

Engineered pavement systems have been perfected over many decades. Manufactured plastic edge restraints are a recent evolution to an already proven system. Unfortunately, many edge restraints do a poor job of holding pavement energy and maintaining system interlock. This architectural specification for edge restraints is based on proven performance of properly constructed segmental pavements using current industry installation standards.

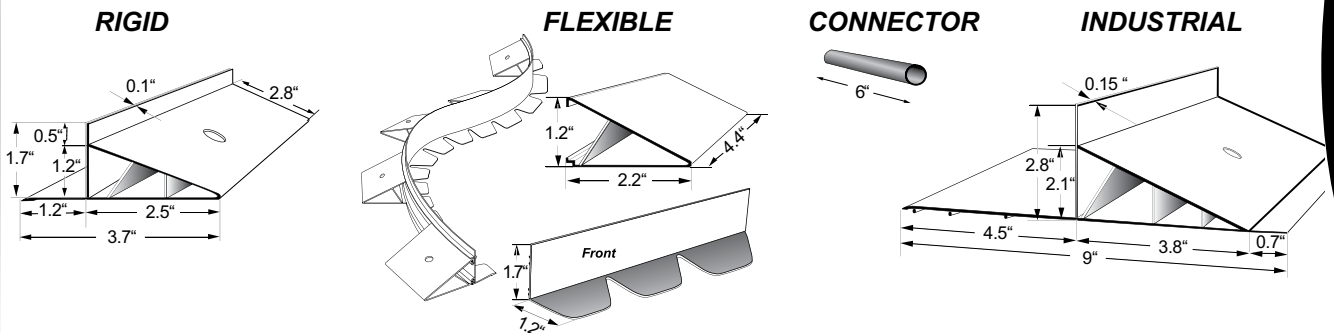

SEGMENTAL PAVER EDGE RESTRAINTS
SPECIFICATIONS

SPECIFICATIONS for SEGMENTAL PAVEMENT PAVER EDGE RESTRAINTS:

Part 1 – GENERAL

1.1 Scope of Work

- A. Installation of plastic paver edge restraints on dense-graded aggregate base.

Note: Separate plastic paver edge restraint installation specifications are available for specialty applications

1. Geo/Bedding Wrap Method for open-graded base (permeable)
2. Geo/Bedding Wrap Method for other flexible base

www.paveedge.com

1.2 System Description

- A. Segmental paver systems installed over compacted dense-graded aggregate base material with a nominal 1" (25 mm) layer of bedding sand using a plastic edge restraint.

1.3 Submittals

- A. 3 ft (90 cm) samples of edgings to be used, properly marked and identified by manufacturer and distributor with accompanying manufacturer MSDS.

- B. Products submitted should incorporate the following features and components identified in a drawing with submittal. (see Section 2.1)

1.4 Tests

- A. Submit a STORK METHOD engineering test report showing Deformation and Load performance data meeting minimum requirements, as defined in Section 2.2

1.5 Storage Conditions

- A. Always store edgings flat and out of direct sunlight. Leave boxed or bundled until used.

Part 2 – PRODUCT

2.1 Edging Properties

- A. PROFILE** – Should incorporate the following components
1. Edge restraint footprint surface must be solid and uniform containing voids no larger than 50%.
 2. Frost heave/sand retention lip, extending a minimum ½” (13 mm) under the bedding layer with a minimum of 75% coverage along the length of the edging.
 3. Frictional resistance rib(s) having a minimum of one rib under the lip.

B. COMPOSITION – Polyvinyl Chloride (PVC)

C. MATERIALS

1. Rigid style edging for straight runs and gradual curves.
2. Flexible style edging for sweeping and tight radius curves with the flexibility to create a radius as small as 24” (600 mm).
3. Height minimum of 1 5/8” (41.3 mm)
4. Connection piece shall provide complete end to end contact on all pavement facing edges without piece to piece lippage. Connection device shall extend beyond splice at least 2” (51 mm) in each direction from splice.
5. Anchoring to be completed with 10” (25 cm) long x 3/8” (1 cm) diameter steel landscape spikes
 - Maximum spike spacing for rigid style edging = 24” (600 mm)
 - Maximum spike spacing for flexible style edging = 12” (300 mm)

2.2 Edging Performance

A. Edging performance must meet minimum requirements based on the STORK METHOD (see Appendix A for STORK METHOD definition).

B. SPECIFICATIONS

1. Deformation

Rigid style: Maximum Deformation = 0.0044” (0.112 mm)

Flexible style: Maximum Deformation = 0.0154” (0.4 mm)

2. Load

Rigid style: Minimum Load = 252 lbf* (1.1214 kN)

Flexible style: Minimum Load = 230 lbf* (1.0235 kN)

*lbf = pounds force, kN = kilonewton

**Electronic online copy available at:
www.paveedge.com**

Part 3 – EXECUTION

3.1 Base Preparation

- A.** Follow project engineer’s specifications for dense-graded base and base extension. Refer to ICPI and BIA base guidelines in absence of sufficient project specifications regarding base and base extension preparation.

3.2 Edging Installation

A. Installing edging BEFORE bedding sand and pavers

1. Per industry recommendations, place edging on compacted base. Never allow edging to be installed on top of the bedding layer.
2. Spike rigid style edging using predrilled holes, with a maximum spacing of 24” (600 mm) between spikes. If holes do not meet spike placement requirements drive spike through the back at required location. When installing flexible style edging with a maximum spacing between spikes of 12” (300 mm).
3. Connect additional sections of edging as needed (see Section 2.1, C-4 for connection)

B. Installing edging AFTER sand & pavers

1. Using a trowel or flat head shovel, cut down along the back of the paver, pulling away the excess bedding sand without disturbing the base material.
2. Connect sections together (see Section 2.1, C-4 for connection).
3. Place edging directly on the base material. Slide the retention lip under the bedding layer. Never allow edging be installed on top of the bedding layer.
4. Spike into place following the same spike placement specifications as in section 3.2, A-2. When installing after bedding layer and pavers, nail the spike at an angle with the point driven inward toward the pavement (toe-nailing). This is a preferred practice to keep edging tight to the pavement.

3.3 Installation of sand and pavers

- A.** Install bedding sand and pavers following project specifications.

3.4 Landscaping

- A.** Soil backfill and remedial landscaping to be completed per contract by others.

SEGMENTAL PAVER EDGE RESTRAINTS SPECIFICATIONS



PAVE TECH, INC.

PO Box 576, Prior Lake, MN 55372 USA Phone: 952-226-6400 Fax: 952-226-6406
sales@paveedge.com 800-728-3832 **PAVETECH.COM**